



LPT40

Lithium Pallet Truck

Patents pending



CAPACITY 4,000 Lbs.

48v 30Ah rechargeable battery
110v external plug-in smart charger

DRIVE AND TRAVEL CONTROLS

48-volt Curtis travel control with permanent magnet drive motor.

Variable speed from 0 mph to 3.4 mph empty
Variable speed from 0 mph to 3.1 mph loaded

WEIGHT

390 lbs. with battery

TIRES

Drive (1) 8.3" x 2.8" polyurethane
Load (2) 2.9" x 3.5" polyurethane

FORKS 27" OAW x 46" OAL standard

Designed for use with standard 48" pallets and other common skids and containers. Forks can achieve a maximum elevation of 7.75" are built for medium duty use and come standard with a fork entry roller for reliable pallet entry.

CONTROL HEAD

Travel, lift & lower functions, and **creep speed** controls are located on the ergonomic control head. All operator controls are accessible without having to lift one's hand from the handle grips. The control head is designed to allow for easy operation with either hand and includes a belly button reversing switch, dual butterfly travel controls, horn, battery discharge indicator, wake-up buttons, and key switch. The low mounted tiller arm offers excellent operator comfort and minimum steering effort.

HYDRAULICS

DC pump and chrome plated cylinder provides for smooth and efficient lifting.

ELECTRICAL

Water resistant connectors and shrouded wiring harness supply power reliably to components. System includes an emergency power disconnect.

BRAKES

Electromagnetic brake provides good stopping power when handle is upright or lowered beyond the operating range.

SERVICEABILITY

Removable covers and modular design of components provides for easy maintenance with simple hand tools. Two piece drive wheel reduces complexity of tire changes.

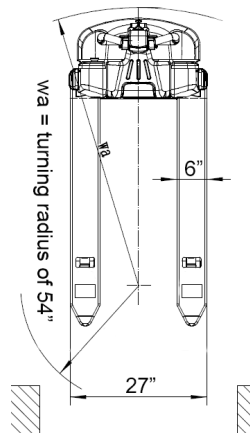
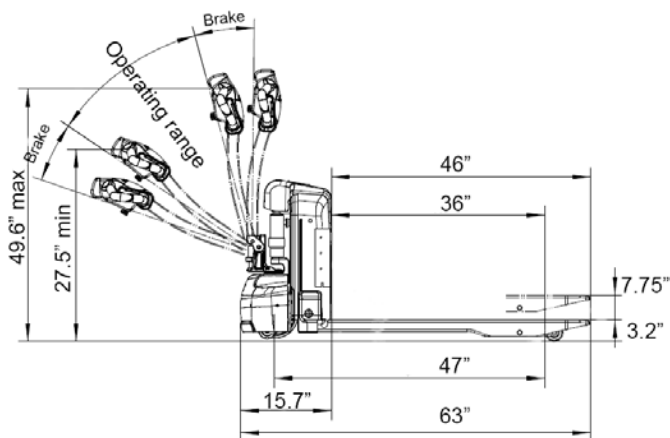

OPTIONAL

- 48" load back rest
- Tool tray with load restraint
- 36" long forks (33.5" actual)
- Traction tire
- Stability casters



www.bigjioeforklifts.com
630-916-2600

Certification
All units are built to be in compliance with the Occupational Safety & Health Act (OSHA)

Big Joe will not assume liability for injuries or damage arising from, or caused by, the removal of any safety devices from their vehicles by user. Because of Big Lift continuing to improve products, specifications are subject to change without notice.

© Copyright 2026, Big JOe Forklifts Printed USA 0320